

MOTOMAN HC10DTF

Human-Collaborative Robots for the Food- and Pharma Industry

6 integrated Sensors

with internal Cable Routing



MOTOMAN HC10DTF (F10, F13) are 6 axes human-collaborative robots with a payload of up to 10 kg. Complying to EN 60529-IP67, they are dust and waterproof protected to operate in harsh environments.

Protection class IP67 for Food Grade Grease and ISO class 5 allow the robot to be used in food related applications in packaging applications, as well as in the Pharma Industry. Its chemical proof surface resists acid or alkaline cleaning fluid. Operator's safety is assured by a Power and Force Limit technology that stops the robot in case of contact with an operator.

The robot arm can be hand guided by an operator and robot positions and gripper operation can be registered via "Teach" and "Tool" buttons. These features offer time saving during the robot programming. The robot's arm geometry was designed to avoid pinch points (finger) and provides internal wiring options (Air (-F10) or Ethernet (-F13)).

The MOTOMAN HC10DTF robots can operate without additional protective measures like a safety fence, depending on the risk assessment. This saves space and costs.

KEY BENEFITS

- Suitable for packaging of food and for the pharma industry
- Chemical proof surface for powerful cleaning

Controller

- Available with YRC1000 or YRC1000micro industrial robot controller

High safety

- Contact force between operator and robot is limited to a safe level
- Safety by Design: rounded edges without pinch points (finger protections)
- Internal cable routing options: Air (-F10) or Ethernet (-F13)
- Safety standards – applications for industrial robots: ISO 10218-1 (5.10.5 Power and Force Limiting)
- Complies to ISO TS 15066 (collaborative robotics) and ISO 14644 (Cleanroom class 5)
- Safety functions industrial robot controller: ISO 13849-1, PLd, Cat. 3
- Functional Safety Unit included
- Safe Force/Torque Sensors in all 6 links

Easy teaching

- Move the robot arm directly via hand guiding function with Smart Pendant or common robot Teach Pendant

Safety and Speed

- Depending on the application, the MOTOMAN HC10DTF can be switched between safe/collaborative mode in phases of man-robot-interaction, and returning into high speed when absence of the operator is detected by additional safety devices

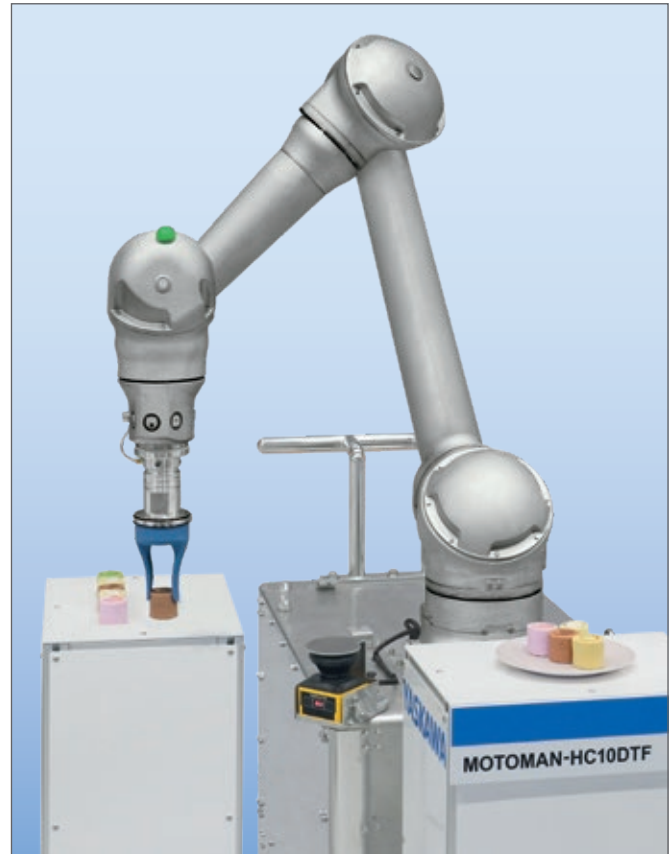

Notes on dust-proof/waterproof specifications

This robot conforms to IP67.

Definition of IP67

- Protection from the entry of dust
- Protection from immersion in water with being submerged for a specified duration and pressure

Details of Cleaning Fluid

Cleaning fluid	Manufacturer	Acid or alkaline	Main component	PH	Dilution ratio
Ratner W54	Nippon Kayaku Food Techno Co., Ltd	Weak acid	Ethanol	6	–
Topax 191	ECOLAB	Alkaline	Sodium hydroxide	12.7 to 13.2	max. 3 %
Topax 56	ECOLAB	Acid	Phosphoric acid	1	max. 3 %
Topaktive DES	ECOLAB	Acid	Aetic acid	2 to 3	max. 3 %

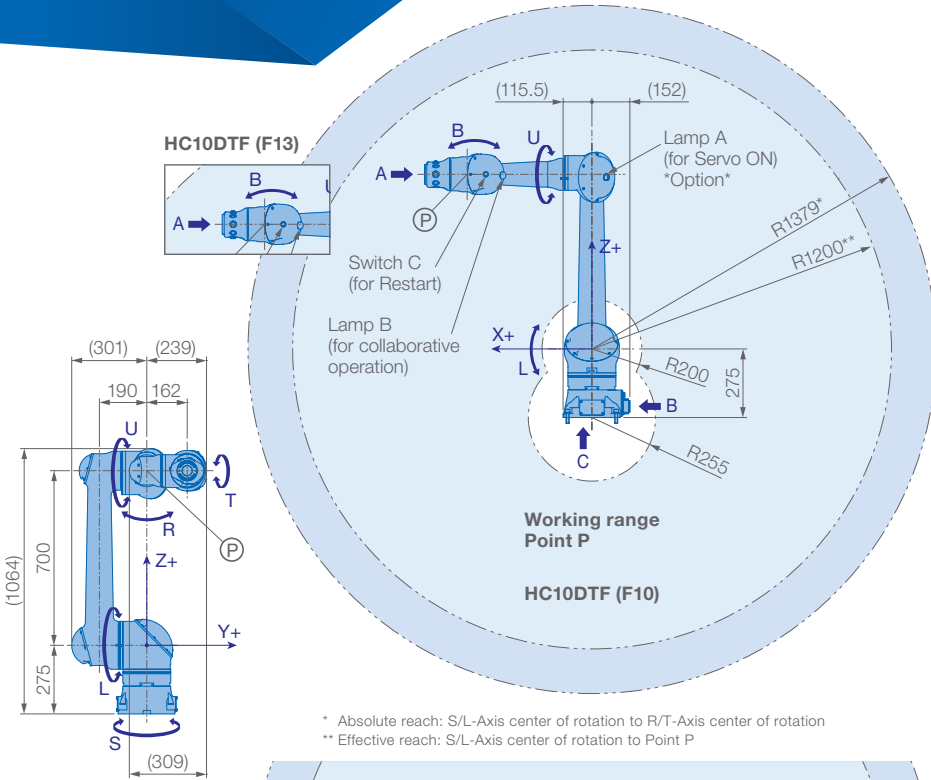

* Absolute reach: S/L-Axis center of rotation to R/T-Axis center of rotation
 ** Effective reach: S/L-Axis center of rotation to Point P

View A

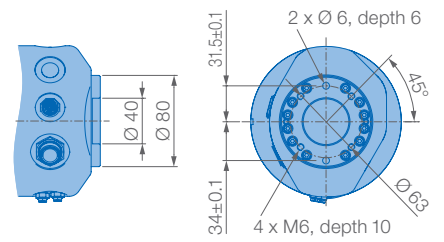

View B

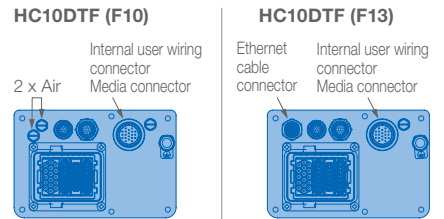

View C

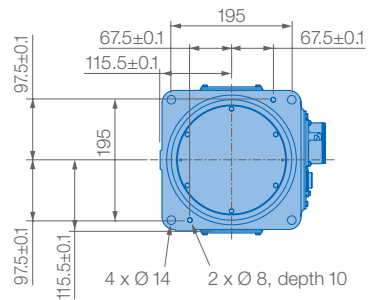

Mounting options: Floor, ceiling, wall, tilt*
 Protection class: EN 60529-IP67

* S Axis motion limits – see table left side

View D

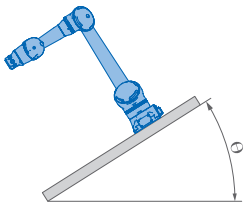
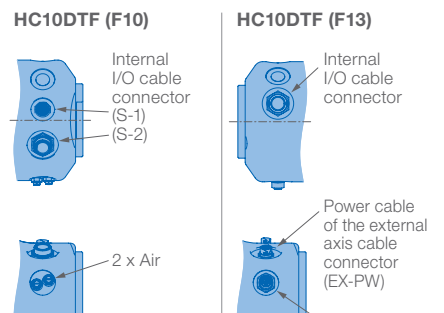

Robot installation angle θ [deg.]	S-axis operating range [deg.]
$0 \leq \theta \leq 25$	no limit
$25 < \theta \leq 40$	± 60 max.
$30 < \theta \leq 40$	± 45 max.
$40 < \theta$	± 30 max.

Prevent interaction of the robot with:

- Corrosive gases, liquids or explosive gases
- Exposure to water, oil or dust
- Excessive electrical noise (plasma)

Allowable wrist load

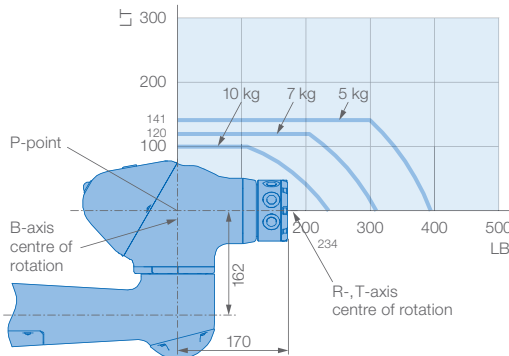

Specifications HC10DTF (F10 + F13)

Axes	Maximum motion range [°]	Maximum speed [°/sec.]	Allowable moment [Nm]	Allowable moment of inertia [kg · m ²]	Controlled axes	6
S	± 180	130	–	–	Max. payload (on U-axis) [kg]	10
L	± 180	130	–	–	Repeatability [mm]	± 0.05
U	+265/–95	180	–	–	Max. working range R [mm]	1379*/1200**
R	± 180	180	27.4	0.78	Temperature [°C]	0 to +40
B	± 180	250	27.4	0.78	Humidity [%]	20 – 80
T	± 180	250	9.8	0.1	Weight [kg]	58
					Power supply, average [KVA]	1.0

* Absolute reach: S/L-Axis center of rotation to R/T-Axis center of rotation ** Effective reach: S/L-Axis center of rotation to Point P

YASKAWA GROUP

- AT Yaskawa Austria
Schwechat/Wien
+43(0)1-707-9324-15
- CZ Yaskawa Czech s.r.o.
Rudná u Prahy +420-257-941-718
- DK Yaskawa Danmark
Løsning +45 7022 2477
- ES Yaskawa Ibérica, S.L.
Gavà/Barcelona +34-93-6303478
- FR Yaskawa France SARL
Le Bignon +33-2-40131919
- FI Yaskawa Finland Oy
Turku +358-(0)-403000600
- GB Yaskawa UK Ltd.
Banbury +44-1295-272755
- IT Yaskawa Italia s.r.l.
Torino +39-011-9005833
- IL Yaskawa Europe Technology Ltd.
Rosh Ha'ayin +972-3-9004114
- NL Yaskawa Benelux B.V.
Eindhoven +31-40-2895500
- PL Yaskawa Polska Sp. z o.o.
Wrocław +48-71-7928670
- RU Yaskawa Europe Holding AB
Moskva +46-480-417-800
- SE Yaskawa Nordic AB
Torsås +46-480-417-800
- SI Yaskawa Slovenia
Ribnica +386-1-8372-410
- TR Yaskawa Turkey Elektrik
Ticaret Ltd. Sti.
İstanbul +90-216-5273450
- ZA Yaskawa Southern Africa (PTY) Ltd
Johannesburg +27-11-6083182

DISTRIBUTORS

- BG ATRI ROBOTICS Ltd.
Stara Zagora +359 899 625 160
Kammarton Bulgaria Ltd.
Sofia +359-02-926-6060
- EE RKR Seadmed OÜ
Tallinn/Estonia +372-68-35-235
- GR Gizelis Robotics
Schimatari Viotias +30-2262057199
- HU Flexman Robotics Kft
Budapest +36 1 259 0981
- LT Profibus UAB
Panevezys +370-45-518575
- NO Skala Robotech AS
Lierstranda +47-32240600
- PT ROBOPLAN Lda
Aveiro +351-234 943 900
- RO NORMANDIA S.R.L.
Braşov +40 268 549 236



Yaskawa Headquarters

Yaskawa Europe GmbH
Robotics Division
Yaskawastraße 1
85391 Allershausen, Germany
Tel. +49 (0) 8166/90-0
Fax +49 (0) 8166/90-103

robotics@yaskawa.eu.com
www.yaskawa.eu.com

Yaskawa Academy and sales office Frankfurt

Yaskawa Europe GmbH
Robotics Division
Hauptstraße 185
65760 Eschborn, Germany
Tel. +49 (0) 6196/77725-0
Fax +49 (0) 6196/77725-39

All drawing dimensions in mm.
Technical data may be subject to change without previous notice.
Please request detailed drawings at robotics@yaskawa.eu.com.

YR-1-06VXHC10-F10, YR-1-06VXHC10-F13
B-10-2021, A-No. 210158

YASKAWA